

Cammatic: An Approach to Improve DSS 13 Antenna Gravity-Loading Performance

R. Levy and D. Strain¹

Ground Antennas and Facilities Engineering Section

Corrective actuator forces are applied to the DSS 13 antenna structure to improve its accuracy. These forces are calibrated according to the antenna elevation requirements. The calibration is derived from accurate field measurements and is not subject to the errors that result from computer modelling. A successful demonstration has provided significant antenna surface improvement. An improvement of 0.6 to 1 dB is predicted.

I. Introduction

As originally assembled and measured in the summer of 1991, the DSS 13 34-m antenna's performance was inconsistent with and inferior to finite-element-method computer model predictions. Details of this evaluation were presented in a report.² Figure 1 shows that the errors derived from actual measurements at Ka-band frequencies (32 GHz) were larger than the errors predicted by either the NASTRAN or IDEAS computer program models.

At that time, the antenna contained both central and off-to-the-side beam waveguide shroud cylinders. As can be seen in Fig. 2, these shrouds are substantial structures and are capable of introducing significant and complex forces that could not readily be modelled accurately by computer. Strain gage measurements on both shrouds

indicated force magnitudes of about 75 kN on the bypass shroud and half as much on the central shroud. A computer-modelling analysis showed that structural interaction forces, caused by connecting the shrouds firmly to the remaining structure, could have a significant effect on performance. The study also showed that the bypass shroud forces had more effect than the central shroud forces.

However, an examination of the strain gage measurements showed the direction of the forces to be opposite to those determined from the model investigation. That is, when the model predicted tensile forces on the shroud, the strain gage forces were compressive, and vice versa. Dial-indicator measurements of the relative displacement between shroud and structure were also consistent with the strain gage forces measured on the shrouds. At the time of the report, this reversal of shroud forces was attributed to a dominating eccentricity in the alignment of the shroud bearings relative to the elevation axis.

¹ Planning Research Corporation (PRC).

² R. Levy, "DSS 13 Antenna Structure Measurements and Evaluation," JPL Report D-8947 (internal document), Jet Propulsion Laboratory, Pasadena, California, October 1, 1991.

Some time later, it was proposed to remove the bypass shroud—no longer a microwave requirement—to free the structure from the associated interaction forces. There was general agreement that the structural performance would improve by eliminating the bypass. The forces were thought to act unsymmetrically on the structure and therefore were inconsistent with the objective of homologous structural response. Theodolite and holography measurements had clearly established unsymmetrical and non-homologous surface distortion patterns with the bypass shroud in place.

II. History After Bypass Shroud Removal

The bypass was removed in December 1991, and surface panels were reset to accommodate the change in structural configuration. Theodolite, holography, and gain measurements were obtained. These measurements all indicated that the surface was no better, from a microwave standpoint, and more likely somewhat worse, than with the bypass shroud in place. On the other hand, surface deformations were symmetrical and smooth, and a large surface disturbance near the former bypass had disappeared. Furthermore, theodolite measurements of the gross structure deflections were impressively consistent with model predictions. Unfortunately, the much smaller residual deflections obtained by least-square fitting the gross deflections to the nearest homologous surface were larger than anticipated.

III. Evaluation and Proposed Improvement

Since the forces developed by attaching the bypass shroud to the structure could deteriorate the antenna's performance and because these forces were observed to be in the opposite direction to those expected from its attachment to the structure, it now appears that forces from the shroud, although not symmetrical and homologous, were actually helping performance. These forces were explained as accruing from a fortuitous shroud bearing misalignment, such as might result from cam-like effects. It was proposed to recover the beneficial effects of these cam-like forces by applying calibrated active forces through symmetrically placed actuators from the alidade to the surface-supporting structure. Actuators, rather than permanent structural member attachments, were needed because the analysis had demonstrated that passive forces from attachments would act in a direction opposite to that required for improvement.

Figure 3 shows a proposed new actuator structure and system to apply the cam-like forces. This system has the

capability of applying forces parallel to the Z and X axes shown in the figure. It incorporates a few new structural bar members (shown in heavy lines) to support the actuators and to apply forces to the antenna structure.

Comprehensive computer modelling studies were made to determine the optimum magnitudes and force directions to be applied at each antenna elevation. The computer effort was based upon a hybrid model: the original antenna's response was derived from a theodolite surface survey, while the additional actuator forces' response was derived from the original finite element model. The computational procedures were based upon [1]. The objective was to obtain the greatest overall improvement.

It was found that, although the greatest improvement could be obtained by optimizing both Z - and X -axis forces, there was only a small reduction in efficiency when the Z -axis actuators were eliminated and only one pair of X -axis actuators was used. This provided a major simplification of the system because the necessary new forces could readily be applied by reacting against the existing massive elevation-bearing housings. Figure 4 shows one side of the antenna with the X -actuator mechanical assembly that was designed and installed. Figure 5 is a photograph of the antenna in which the pair of actuator structures on each side appears darker than the remaining antenna structure in the background.

Figure 6 shows the gain prediction with the proposed X -axis actuators, compared with the previously measured gain curve. For example, an improvement of about 1 dB at 10 deg elevation and about 0.6 dB at 80 deg elevation can be anticipated from the figure. Such changes would provide valuable improvements in the antenna performance. Another favorable feature of the actuator system is that the forces are relatively small, so they are easily accommodated by actuators and the existing structure. Figure 7 shows the magnitudes of the anticipated optimum X -axis actuator forces. At most, the forces would be only two percent of the weight of the structure to which they were applied.

IV. Results of Field Gain Measurements

Gain measurements were made from 4 to 11 p.m. local time on March 18, 1993, by observations at 32 GHz on radio source star 3C84. The star traversed downwards from above 80 deg to just below 10 deg of elevation during this time. The procedure was to observe with and without actuator forces, applied in the range of those in Fig. 7.

The forces were applied by hydraulic jacks, and pressures were adjusted manually according to directions from the control room.

Figure 8 shows the antenna gains computed from the measurements. Solid lines are drawn between the measurements to identify the cases without actuator forces. It can be seen that the gain with actuator forces, with one trivial exception, is always higher than the solid lines. It is not possible to compute the differences in the gains by a direct subtraction because no two measurements of the moving star were made at the same elevation. Nevertheless, since there were almost 20 measurements with no actuator forces, it was reasonable to fit a curve through these points. Therefore a sixth-degree polynomial was developed to provide a close fit as a basis for interpolation at the elevations where the forces were applied.

Figure 9 shows the improvements in gain with the actuator forces, which are obtained by subtracting the interpolated gain without actuator forces. The solid curve in the figure is the predicted improvement, which is equivalent to the differences between the curves in Fig. 6. It can be seen that the measured improvements are distributed both above and below the prediction curve. Actually, more points are above the prediction curve than below.

V. Summary and Conclusions

Measurements have confirmed that this is an effective, simple, and practical way to improve the performance of this antenna. In accordance with the predictions, improvements of about 1 dB at 10 deg elevation and more than 0.6 dB at 75 deg elevation were observed. Furthermore, the applied forces may not have been optimum because it was not possible to provide a careful force calibration procedure during the measurements.

One attractive feature of this approach is that antenna performance data are derived from field measurements and are not subject to traditional differences between model predictions and performance measurements. Models are used only for preliminary calibration and assessment.

Another advantage is the simplicity of the construction and control operations in a system that requires only two actuators. Other proposed antenna actuator systems require tens to hundreds of actuators distributed throughout main reflector or secondary surfaces. The complexity of fabricating, calibrating, and controlling such unproven systems could be overwhelming.

Acknowledgments

Ron Heuerman designed and detailed the actuator assemblies. Michael Britcliffe established the experimental plan and conducted the measurement program. Both made important contributions to the success of the experiment.

Reference

- [1] R. Levy, "Reanalysis, Compatibility, and Correlation in Analysis of Modified Antenna Structures," *The Telecommunications and Data Acquisition Progress Report 42-97*, vol. January-March 1989, Jet Propulsion Laboratory, Pasadena, California, pp. 367-381, May 15, 1989.

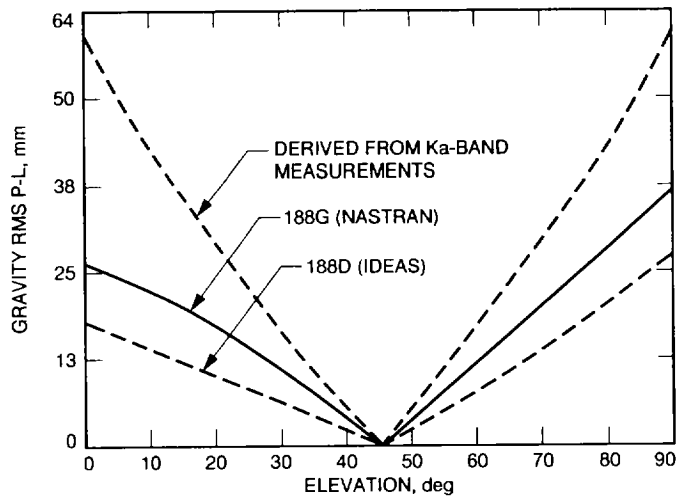

Fig. 1. DSS 13 path-length errors from measurements and computer models.

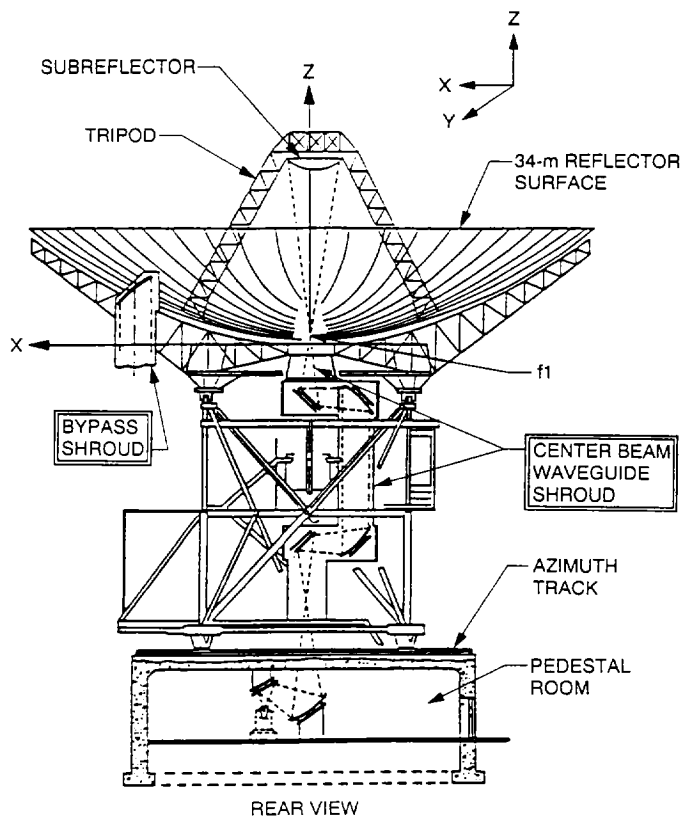

Fig. 2. DSS 13 antenna at zenith (90-deg) elevation.

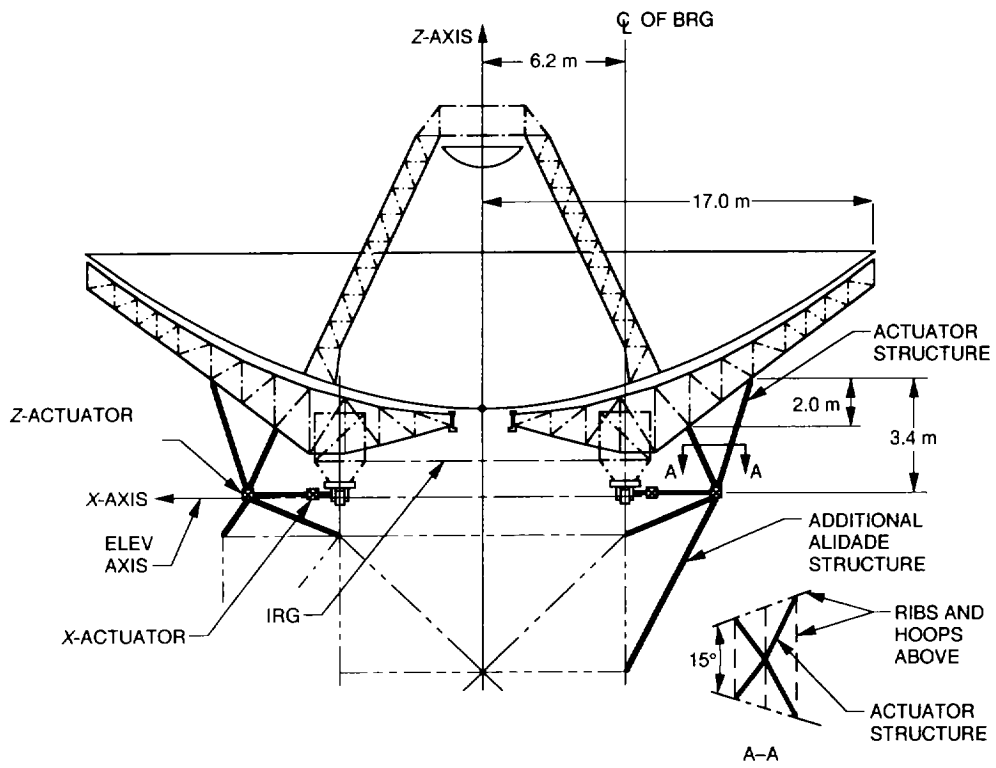

Fig. 3. DSS 13 proposed additional structure-actuator system.

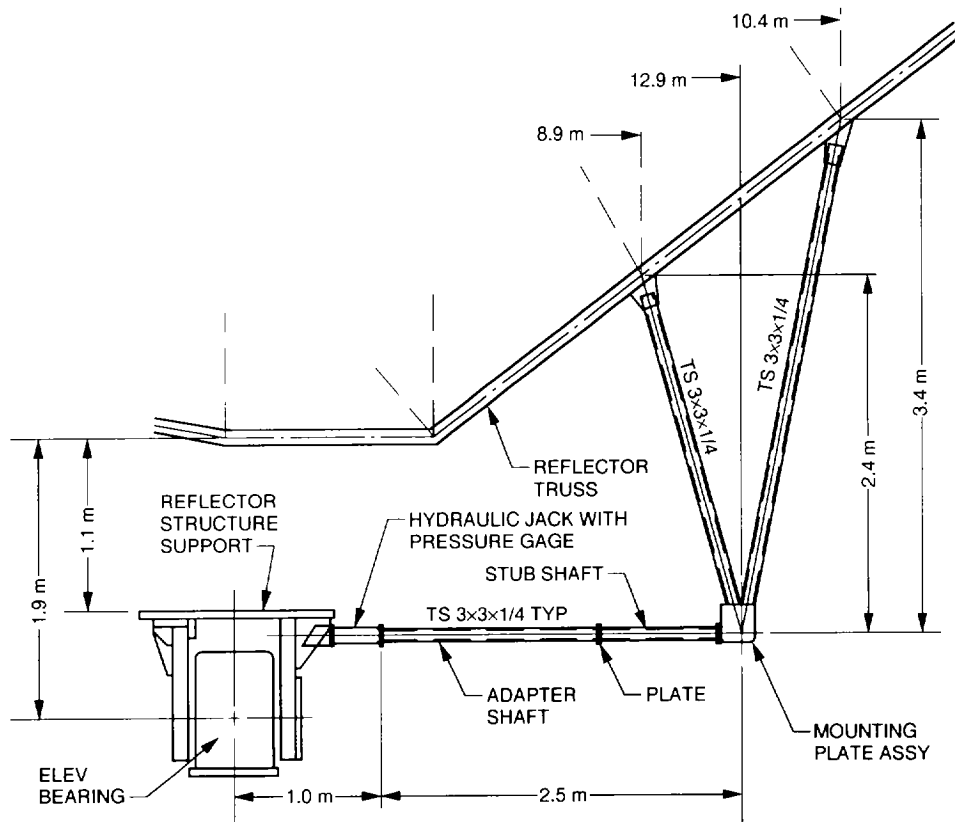

Fig. 4. Elevation view of truss tension/compression.



Fig. 5. X-actuators in place.

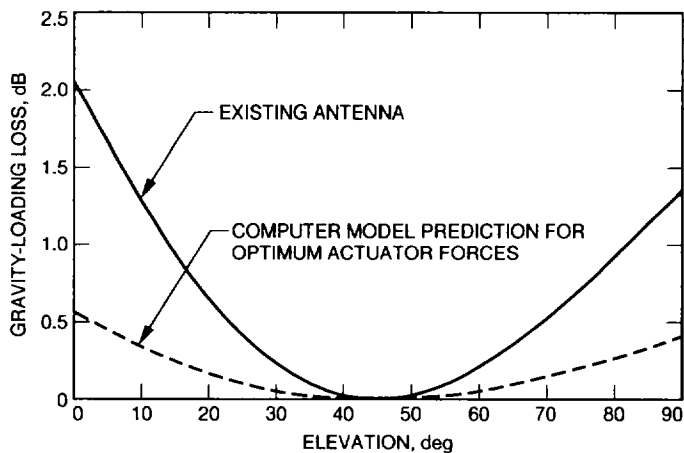

Fig. 6. DSS 13 Ka-band performance with X-axis actuators.

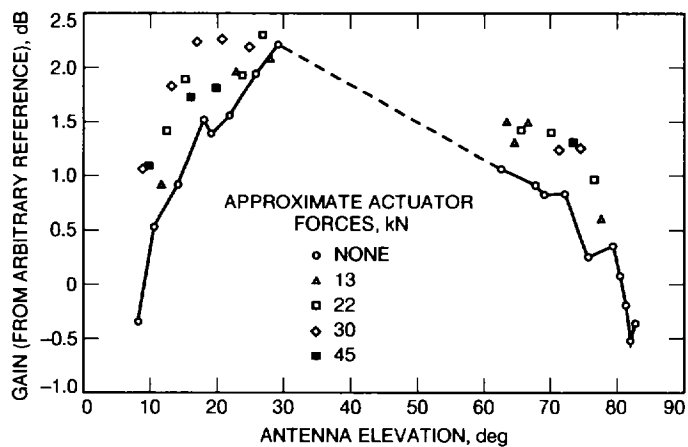

Fig. 8. Preliminary processing of DSS 13 actuator measurements (3-18-93).

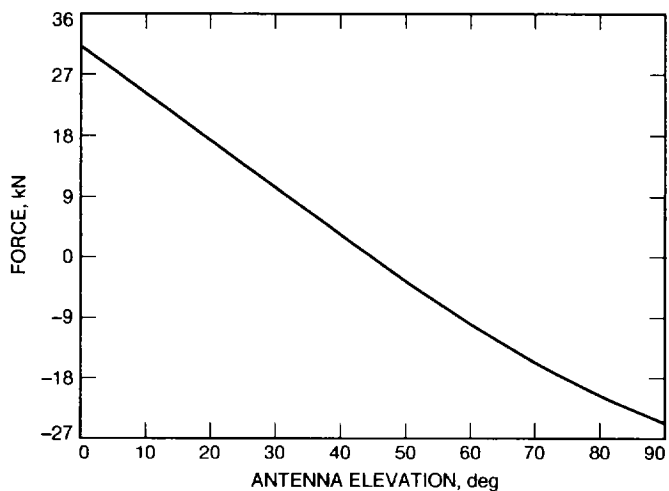

Fig. 7. DSS 13 predicted optimum X-actuator forces.

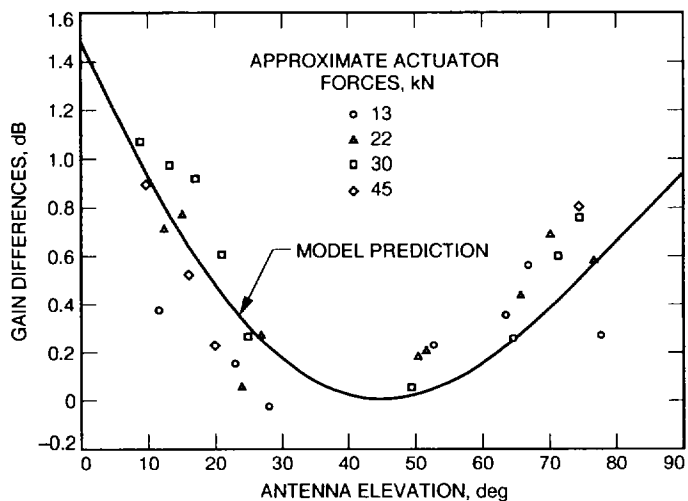

Fig. 9. DSS 13 antenna gain changes with X-axis actuators.