

Errata

The following corrections are made in “Data Format Classification for Autonomous Radio Receivers,” by M. Simon and D. Divsalar, which appeared in *The Interplanetary Network Progress Report*, vol. 42-159, published on November 15, 2004:

In Figs. 1, 3, and 4 (on pp. 4, 11, and 16), the input to the box labeled “Delay $T/2$ ” should come from the output (as opposed to the input) of the half-symbol integrate-and-dump filter. The corrected figures are as follows:

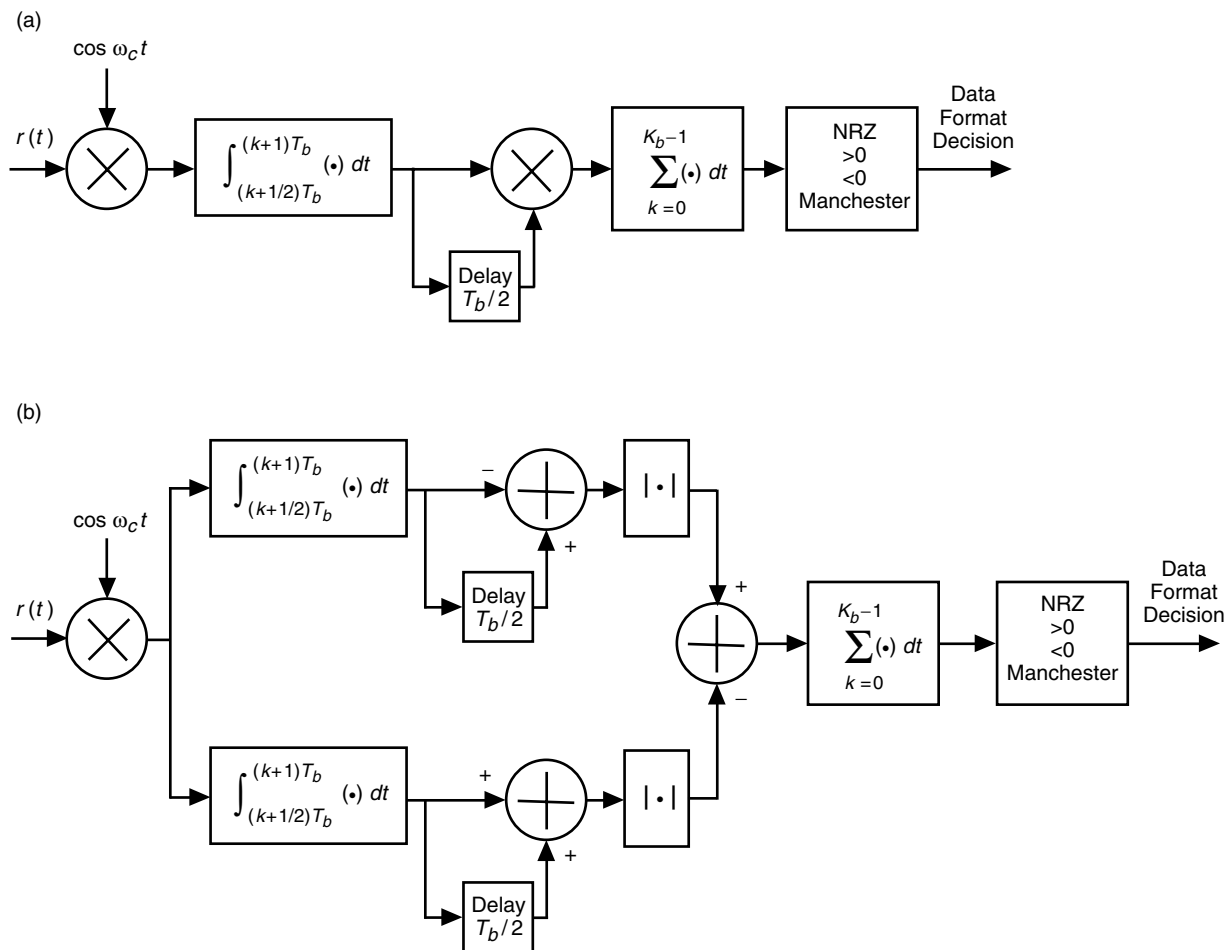

Fig. 1. Reduced-complexity coherent data format classifiers for BPSK: (a) low SNR and (b) high SNR.

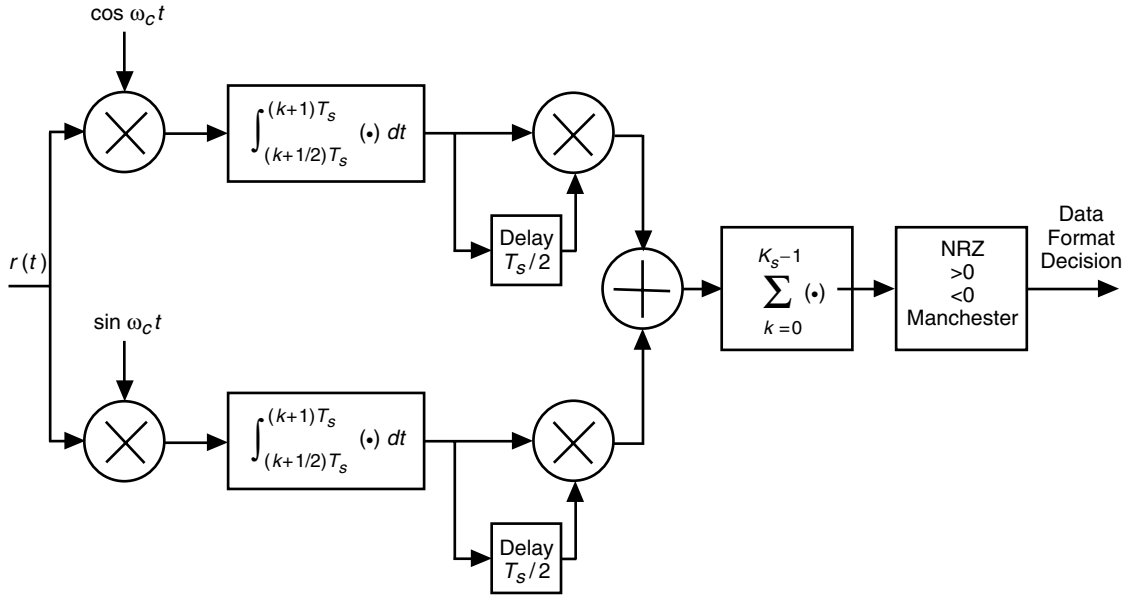

Fig. 3. Reduced-complexity coherent data format classifiers for QPSK: low SNR.

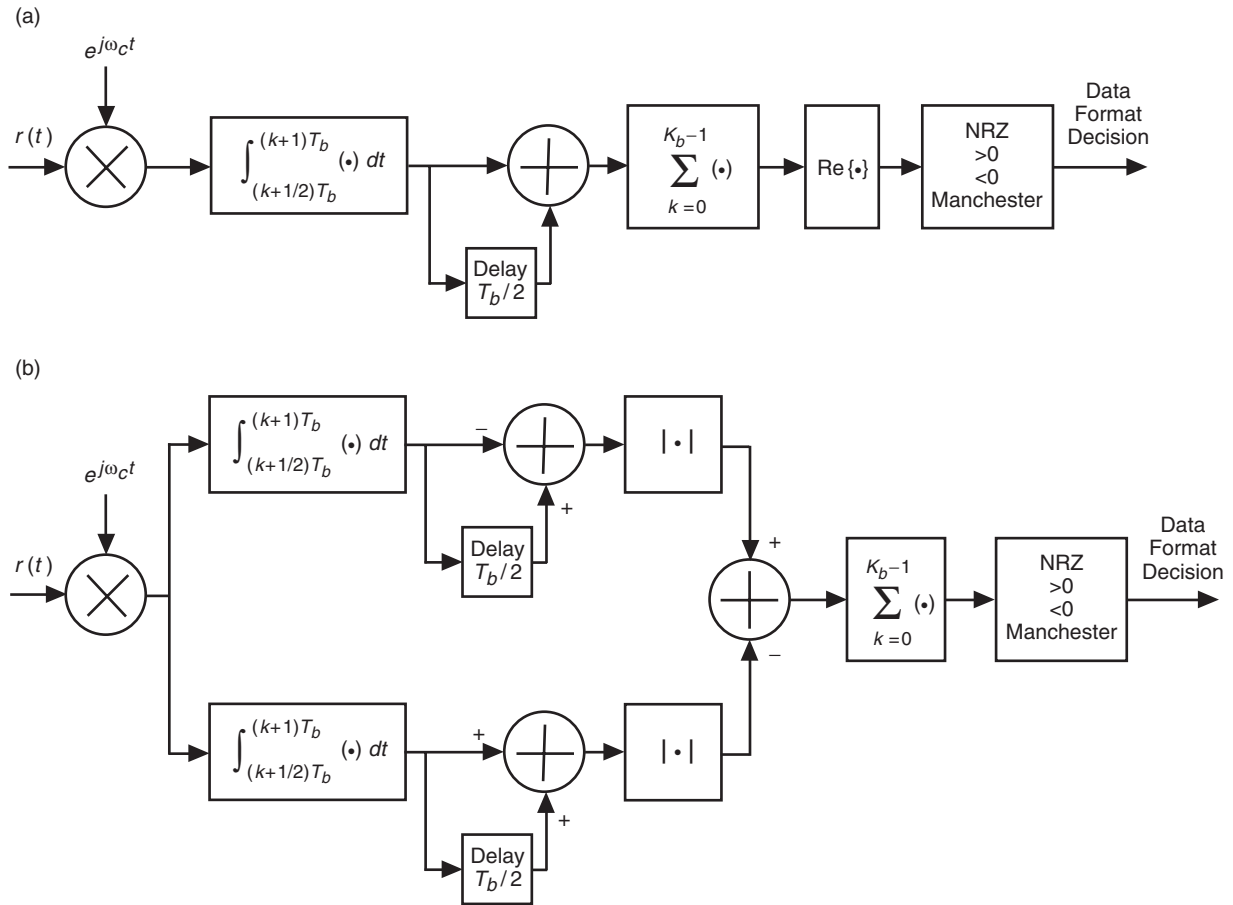

Fig. 4. Reduced-complexity noncoherent data format classifiers for BPSK modulation: (a) low SNR and (b) high SNR.