

# Operating and Environmental Characteristics of Sigma Tau Hydrogen Masers Used in the Very Long Baseline Array (VLBA)

T. K. Tucker

Communications Systems Research Section

*This article presents the results obtained from performance evaluation of a pair of Sigma Tau Standards Corporation Model VLBA-112 active hydrogen maser frequency standards. These masers were manufactured for the National Radio Astronomy Observatory (NRAO) for use on the Very Long Baseline Array (VLBA) project and were furnished to the Jet Propulsion Laboratory (JPL) for the purpose of these tests.*

*Tests on the two masers were performed in the JPL Frequency Standards Laboratory (FSL) as a cooperative effort with NRAO and included the characterization of output frequency stability versus environmental factors such as temperature, humidity, magnetic field, and barometric pressure. The performance tests also included the determination of phase noise and Allan variance using both FSL and Sigma Tau masers as references. All tests were conducted under controlled laboratory conditions, with only the desired environmental and operational parameters varied to determine sensitivity to external environment.*

## I. Introduction

### A. Purpose

The tests described herein were performed by the Jet Propulsion Laboratory (JPL) as a cooperative effort with the National Radio Astronomy Observatory (NRAO). JPL was chosen for this evaluation because of its unique testing capability and facilities, and in order to provide an independent evaluation of Sigma Tau hydrogen maser performance.

All tests were conducted at JPL in the Frequency Standards Research Laboratory Test Facility in Pasadena, California, between March and September 1988.

### B. Sigma Tau Hydrogen Masers

The Model VLBA-112 is a compact and ruggedized active hydrogen maser manufactured by the Sigma Tau Corporation for NRAO for use on the Very Large Baseline Array (VLBA)

Project. The essential physical and electrical characteristics, as given by the manufacturer, are outlined in Table 1.

Prior to performance and environmental testing, the critical operating parameters of each of the masers, identified as Serial Numbers 2 and 3, were determined and recorded as shown in Table 2.

### C. Test Facilities

The JPL Frequency Standards Laboratory is responsible for the research, development, and implementation of a wide variety of state-of-the-art frequency generation and distribution equipment used within the Deep Space Network (DSN). In order to achieve the demanding performance and reliability requirements, a substantial amount of assembly and subassembly testing is required. Toward this end, an extensive testing capability has been developed which includes special equipment, facilities, procedures, and personnel skilled in the testing and characterization of precision oscillators and other signal sources.

The stability and environmental tests which are routinely performed in this facility are as follows:

- (1) Allan variance
- (2) Spectral density of phase
- (3) Temperature sensitivity
- (4) Humidity sensitivity
- (5) Barometric pressure sensitivity
- (6) Magnetic field sensitivity

The instrumentation and test area has approximately 250 square meters of floor space and houses the necessary instrumentation and test equipment. Additionally, two active hydrogen maser frequency references are conveniently located in this area. All critical equipment, including the units under test, are powered by an uninterruptable power source. The entire test area, as well as the environmental control system, is backed up by an automatically switched motor generator. Temperature control is maintained to within  $\pm 0.05$  degrees Centigrade through the use of a doubly redundant air conditioning system. Magnetic field variations are minimized by the use of nonmagnetic construction materials throughout the facility. As an additional precaution, one of the reference hydrogen masers is housed in a magnetically shielded enclosure.

Environmental testing capability is provided by three Tenny Corporation environmental test chambers. Each chamber includes 6 square meters of floor space and is approximately 3 meters high, providing adequate space for equipment under test as well as required cables and peripherals.

The environmental testing capabilities are as shown in Table 3.

### D. Test Plan

All tests were performed by FSTL personnel, in accordance with a test plan. This plan was prepared to establish the procedures and environmental conditions to be followed during the course of testing. The test plan is not intended to be a detailed test procedure, but is rather a description of the specified tests (i.e., spectral density of phase, Allan deviation, frequency stability, etc.), test conditions (i.e., temperature, humidity, barometric pressure) and documentation requirements. The plan also serves as a guide in the planning and scheduling of the overall test program. A copy of the test plan is included in the Appendix.

### E. Measurement Systems

Figure 1 is a block diagram of the measurement system used to determine frequency stability and the Allan variance (deviation) between the Sigma Tau masers and the laboratory reference masers. Figure 2 is a block diagram of the measurement system used to determine the spectral density of phase of the two Sigma Tau masers at the 5, 10, and 100 MHz outputs.

## II. Test Results

### A. Sequence of Tests

The tests and test limits are shown in Table 4.

### B. Allan Variance and Spectral Density of Phase Tests

Figures 3, 4, and 5 are plots of the Allan variance between the two Sigma Tau masers and also between each of the Sigma Tau masers and one of the laboratory reference masers which serve to verify near equal performance of the two Sigma Tau masers. Included in Fig. 2 is the measurement system noise floor. Figures 6, 7, and 8 are plots of the spectral density of phase between the two Sigma Tau masers at the 5, 10, and 100 MHz outputs. The spurious signals seen in each of the plots are predominantly the result of the autotuner modulation signal with some additional contribution from power supply noise.

### C. Environmental Tests

The purpose of these tests was to characterize each maser in terms of frequency shift for a given change in environmental condition. In each test, the output frequency was carefully monitored while one of the environmental conditions was

varied as specified in Table 4. The results of each of these environmental tests are itemized below:

- (1) **Output Frequency versus Temperature Tests.** The masers were individually placed in the test chamber and the chamber temperature was cycled between 17 and 27 deg C; the resultant variation in output frequency was plotted. The frequency sensitivity as a function of ambient temperature is shown in Fig. 9.
- (2) **Output Frequency versus Relative Humidity Tests.** With the chamber temperature held constant, the chamber relative humidity was cycled between 20 and 80 percent, with a 48-hour stabilization period at each limit. The observed variations in output frequency versus the relative humidity were well below  $1 \times 10^{-14}$ .
- (3) **Barometric Pressure Tests.** No output frequency variations were observed as the masers were individually subjected to barometric pressures of 6 kPa above and below ambient pressure with a two-hour dwell at each extreme.
- (4) **Magnetic Field Sensitivity Tests.** In order to determine the maser magnetic field sensitivity, a 230-cm ( $\approx 90$ -inch) Helmholtz coil was placed around the maser. The coil was positioned to provide a vertical

magnetic field and was centered around the maser physics unit. Since the magnetic shielding effectiveness is dependent upon the magnitude of the magnetic field, the sensitivity was measured at three different field values. The magnetic field sensitivity of each maser is shown in Table 5.

- (5) **Output Frequency versus Power Supply Variations.** With the internal battery supply disconnected, the input DC voltage was varied between 24 and 28 VDC. No output frequency shift was observed as a result of these supply variations.

### III. Summary

A summary of the environmental sensitivities of the two Sigma Tau masers is presented in Table 6.

Throughout the test series the Sigma Tau masers performed reliably, and were well-behaved. Of particular interest is the fact that both masers were transported from Socorro, New Mexico to Pasadena, California, a distance of some 800 miles, in the back of a carry-all van. Only a minimum of protection from shock and vibration was provided during transit, and upon arrival both masers were within normal operating parameters.

## Acknowledgments

The author wishes to acknowledge the generous contributions of several individuals to this effort; in particular, that of Albert Kirk and Bill Deiner of JPL for their assistance in the performance of the many tests. Additionally, the generous technical assistance of Harry Peters of the Sigma Tau Corp. during the initial setup and preparation for testing is gratefully acknowledged.

## References

- [1] H. Peters, B. Owings, T. Oakley, and L. Beno, "Hydrogen Masers for Radio Astronomy," *Proc. 41st Ann. Freq. Control Symposium*, pp. 75-81, 1987.
- [2] H. Peters, "Design and Performance of New Hydrogen Masers Using Cavity Frequency Switching Servos," *Proc. 38th Ann. Freq. Control Symposium*, pp. 420-427, 1984.
- [3] *Operation and Instruction Manual, Atomic Hydrogen Maser Frequency Standard, Model VLBA-112*, Sigma Tau Standards Corporation, 1985.

**Table 1. Physical and electrical characteristics**

Size	cm	in.
Height	107	42
Width	46	18
Depth	76	30
Weight	kg	lbs
	238	525
Input power*	AC	DC
	115 V ± 10% rms	24–28 V
	50–60 Hz	4 A (typ.)
	140 watts	
Outputs	MHz	V, rms
	100 (2 ea.)	1 ± 0.3
	10 (1 ea.)	≈ 0.5
	5 (1 ea.)	1 ± 0.3

\*Build-in standby battery supply provides up to 10 hours of operation without input power.

**Table 2. Operating characteristics**

Parameter	S/N 2	S/N 3
Output power, dBm	-100	-100
Line Q	$1.82 \times 10^9$	$1.64 \times 10^9$
Cavity-loaded Q	33,000	37,800
Coupling factor	0.35	0.30
Rx noise figure, dB	<1	<1
Zeeman frequency, Hz	827.7	808.9

Note: All tests were performed in the AUTOTUNE mode.

**Table 3. Environmental test capability**

Parameter	Range
Temperature	15–35 deg C ± 0.05 deg
Pressure	±6 kPa ± 120 Pa
Relative humidity	11–90% RH ± 5%
Magnetic field	±0.5 Gauss

**Table 4. Test sequence and limits**

Parameter	Range
Allan variance	—
Spectral density of phase	—
Temperature	17–27 deg C
Humidity	20–80% RH
Barometric pressure	±6 kPa
Magnetic field	±0.5 Gauss
Power supply variations	24–28 VDC

**Table 5. Magnetic field sensitivity**

Field Magnitude	Sensitivity/Gauss	
	S/N 2	S/N 3
Small (±0.1 G)	$-1.42 \times 10^{-13}$	$-4.74 \times 10^{-13}$
Medium (±0.25 G)	$-1.05 \times 10^{-13}$	$-3.98 \times 10^{-13}$
Large (±0.5 G)	$-8.04 \times 10^{-14}$	$-3.17 \times 10^{-13}$

**Table 6. Environmental sensitivity summary**

Condition	S/N 2	S/N 3
Temperature (17–27°C)	$1.37 \times 10^{-14}/\text{deg C}$	$4.2 \times 10^{-14}/\text{deg C}$
Humidity (20–80% RH)	$<1 \times 10^{-14}$	$<1 \times 10^{-14}$
Barometric pressure (±6 kPa)	$<1 \times 10^{-14}$	$<1 \times 10^{-14}$
Magnetic field (±0.1 Gauss)	$-1.42 \times 10^{-13}/\text{Gauss}$	$-4.74 \times 10^{-13}/\text{Gauss}$
Power supply variations (24–28 VDC)	$<1 \times 10^{-14}$	$<1 \times 10^{-14}$

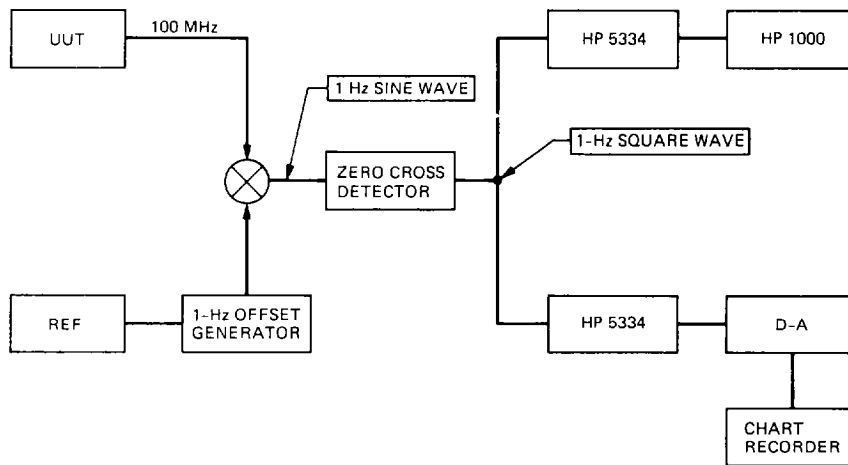

Fig. 1. Measurement system for frequency shift and Allan variance.

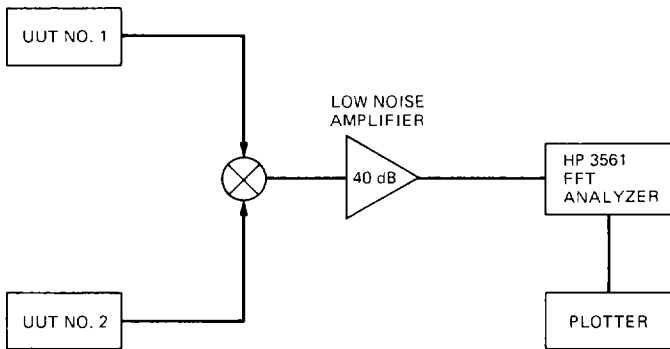

Fig. 2. Phase noise measurement system.

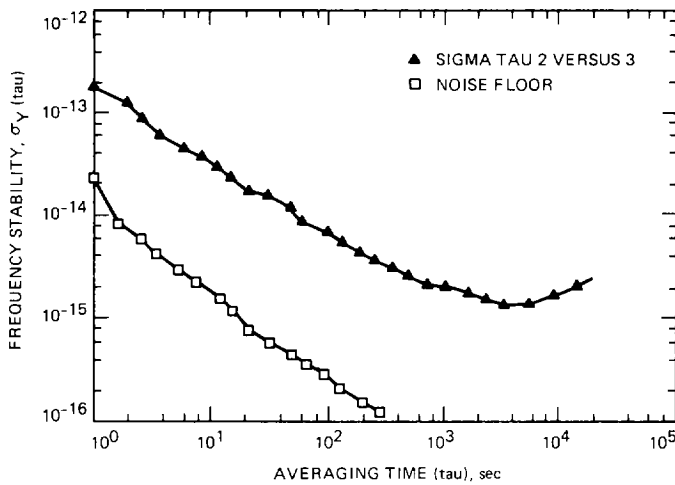

Fig. 3. Allan variance—Sigma Tau 2 versus 3.

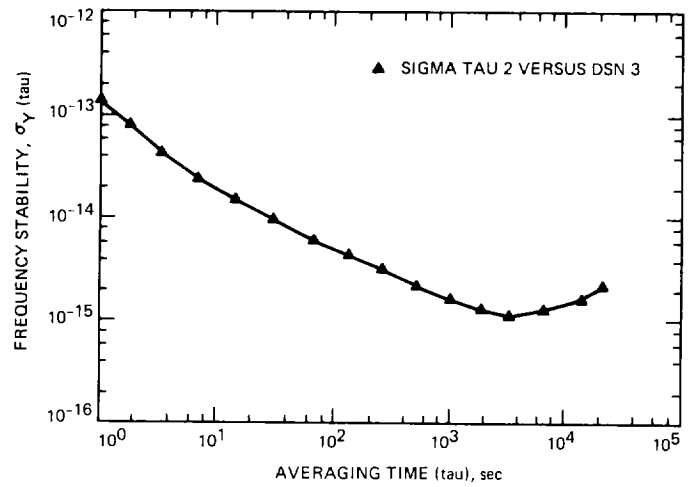

Fig. 4. Allan variance—Sigma Tau 2 versus reference maser.

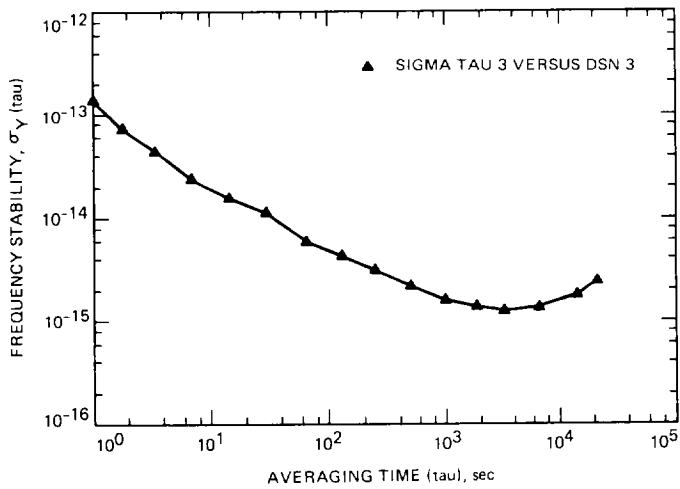

Fig. 5. Allan variance—Sigma Tau 3 versus reference maser.

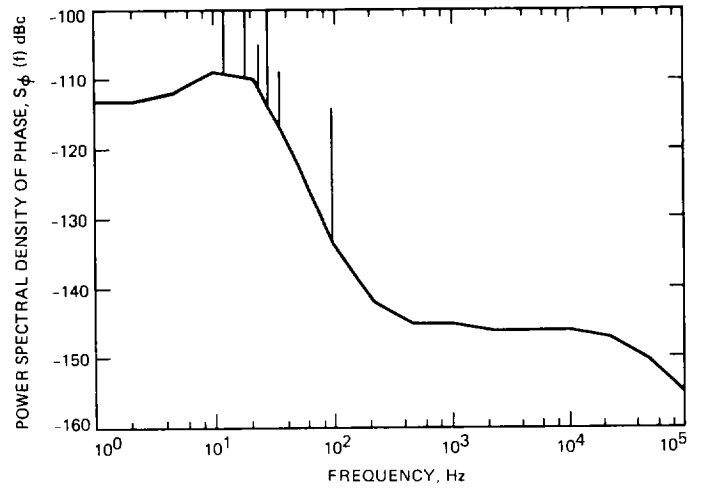

Fig. 7. Phase noise at 10-MHz outputs.

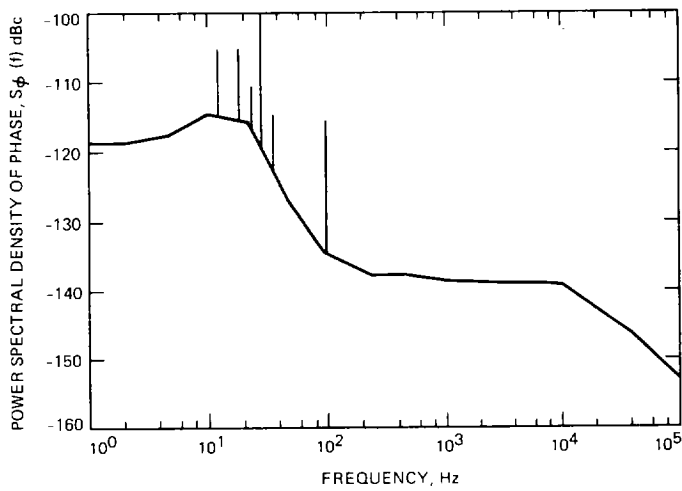

Fig. 6. Phase noise at 5-MHz outputs.

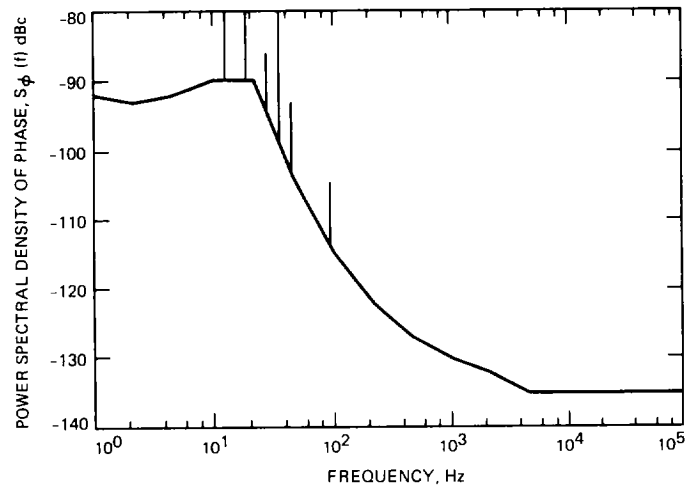
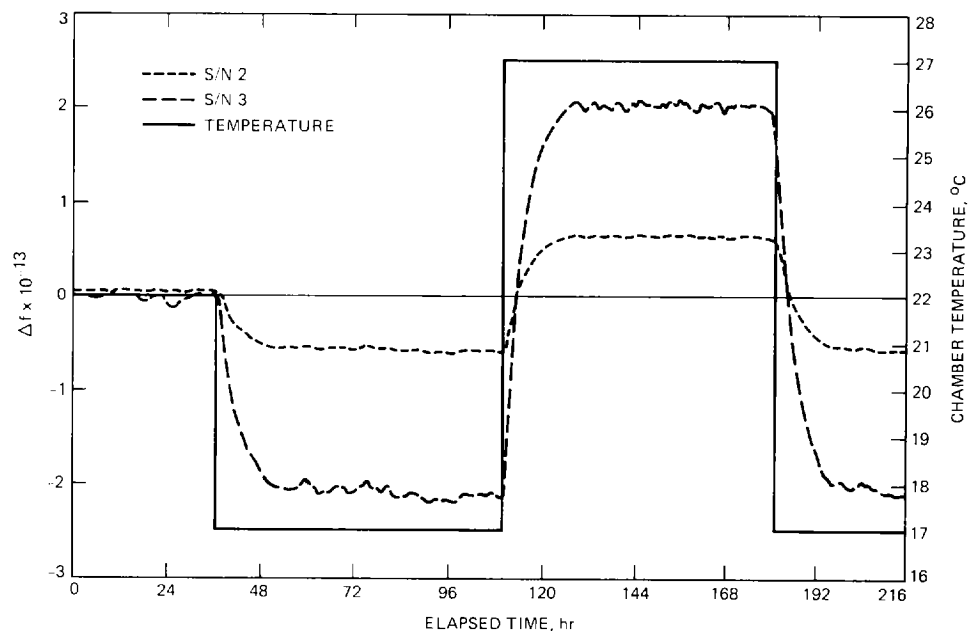

Fig. 8. Phase noise at 100-MHz outputs.



**Fig. 9. Output frequency versus temperature.**

## Appendix

### Outline of a Test Plan for Sigma Tau Hydrogen Masers

#### A. Introduction

1. **General Description.** This test plan outlines the tests and test sequences required to characterize a pair of hydrogen masers and is intended to outline the minimum test requirements, but not necessarily limit the scope of testing.

2. **Objective.** This document establishes the procedures for testing a pair of hydrogen masers manufactured by the Sigma Tau Corporation for the National Radio Astronomy Observatory (NRAO), for use on the Very Large Array (VLA) Project. The maser performance will be tested under laboratory conditions with the environmental and operational parameters varied as specified herein to determine sensitivity to external influences.

3. **Effectivity.** This procedure is effective for the JPL Frequency Standards Laboratory (FSL).

#### B. Applicable Documents

The following documents, of the issue in effect on the date of release of this document, form a part of this document to the extent specified herein:

##### Specifications

*National Radio Astronomy Observatory*

A53308001 Hydrogen Maser Frequency Standard,  
Electrical Requirements

*Sigma Tau Corporation*

Model VLBA-112 Atomic Hydrogen Maser Frequency  
Standard, Operation and Instruction  
Manual

#### C. Test Equipment and Facilities

1. **Test Equipment.** Required test equipment is available in the Frequency Standards Test Laboratory (FSTL) and shall be selected by FSTL personnel as required to perform the tests delineated herein.

2. **Facilities.** All tests described herein are to be performed in the FSTL.

#### D. Test Procedures

1. **Introduction.** Tests in this section are to be performed generally as described. Additional tests may be performed as determined by FSTL personnel.

2. **Test Data.** All test data along with other pertinent information shall be recorded in the appropriate FSTL log book and the "Maser Operating Point and Test Conditions" form as a permanent record of the test results and conditions for each test series. If there is any question, record it in the log!

3. **Initial Tests.** Verify proper operation of each maser under room ambient conditions. Measure and record all operating points and test conditions as baseline data for subsequent tests. As a minimum, the initial tests to be performed are as follows:

- (1) RF output level at each output
- (2) Harmonic distortion at each output
- (3) Phase noise at each output
- (4) Allan variance (24-hour)
- (5) Output frequency versus reference
- (6) Verify proper operation of all operator controls
- (7) Zeeman frequency
- (8) Spin exchange frequency shift
- (9) Offset between autotuner and spin exchange tuning

4. **Power Supply Versus Output Frequency.** Measure the output frequency change versus input supply voltages as follows:

- (1) With PS2 and the external DC supply disconnected, measure the output frequency change as the input AC voltage on PS1 is varied through the range of 105 to 120 VAC.
- (2) With PS1 and the external DC supply disconnected, measure the output frequency change as the input AC voltage on PS2 is varied through the range of 105 to 120 VAC.
- (3) With PS1 and PS2 both disconnected, measure the output frequency change as the external DC supply voltage is varied through the range of 22 to 30 VDC.
- (4) Verify that both AC supplies are reconnected.

5. **Temperature Coefficient of Frequency.** Measure the output frequency change versus temperature over the range of +17 to +27 deg Celsius as follows:

- (1) With the maser stabilized at +22 deg, increase the chamber temperature to +27 deg and allow the maser



to stabilize until the output frequency is stable (48 hours minimum).

- (2) Reduce the chamber temperature to +17 deg and again permit the maser to stabilize.
- (3) Return the chamber temperature to +22 deg and permit the maser to stabilize.

**6. Barometric Pressure Coefficient.** Measure the output frequency versus barometric pressure over the range of ambient  $\pm 6$  kPa ( $\pm 24$  inches of water) as follows:

- (1) With the chamber temperature stabilized at +22 deg Celsius, increase the chamber pressure to 6 kPa above ambient pressure. Permit the maser to stabilize at this pressure (two hours minimum).
- (2) Reduce the chamber pressure to ambient minus 6 kPa and again permit the maser to stabilize at this pressure or soak for two hours minimum.
- (3) Restore the chamber pressure to ambient barometric pressure.
- (4) Repeat the above cycle.

**7. Humidity Test.** Measure the output frequency versus ambient humidity over the range of 20 to 80 percent relative humidity as follows:

- (1) With the chamber stabilized at +22 deg Celsius, elevate the chamber humidity to 80 percent and permit the maser to stabilize at this setting (two days minimum).
- (2) Reduce the chamber humidity to 20 percent and again permit the maser to stabilize at this humidity or soak for two days minimum.

- (3) Open the chamber to ambient humidity conditions, and permit the maser to stabilize for a minimum of two days prior to conducting further tests.

**8. Magnetic Field Coefficient.** With the maser at standard ambient operating conditions of temperature and humidity, install the Helmholtz coil over the maser in a horizontal plane, centered about the cavity. This position yields a vertical magnetic field about the maser cavity shields. Vary the applied magnetic field as follows:

- (1) Increment the applied magnetic field  $\pm 100$  mGauss, and measure the Zeeman frequency, IF level, and frequency shift at each step.
- (2) Repeat step (1) using  $\pm 250$  mGauss increments.
- (3) Repeat step (1) using  $\pm 500$  mGauss increments.

**9. Reverification Tests.** Repeat all of the tests previously listed in Section D.3 above to verify that the maser is operating within normal operating parameters prior to performance of the final Allan variance, drift, and synthesizer calibrations.

**10. Allan Variance.** Perform an Allan variance test for a minimum of 4 days (longer if possible) to obtain data out to  $1 \times 10^5$  seconds.

**11. Synthesizer Calibration.** Adjust the maser synthesizer frequency so that the maser output frequency is equal to the FSTL reference masers.

## E. Concluding Procedures

After completion of the above tests, verify that all test equipment has been disconnected, and that all controls, covers, and connector dust caps are locked in place in preparation for shipment.